

→ **Operation Manual**
SpeedMarker 1300



TROTEC PRODUKTIONS UND VERTRIEBS GMBH

Linzer Straße 156
A – 4600 Wels
AUSTRIA

Tel.: ++43/7242/239-7000
Fax: ++43/7242/239-7380
E-Mail: techsupport@troteclaser.com
www.troteclaser.com

© Copyright

This documentation with all illustrations is intellectual property of Trotec Produktions- u. Vertriebs GmbH. The entire documentation is given to the user for personal use only. This documentation must not be reproduced or made available to others without our written permission. Any breach of law will be prosecuted.



Trotec Produktions- u. Vertriebs GmbH cannot be held responsible for any direct or indirect damages, which result from using or working with the products electric circuits or software described herein. The apparatus must be used only by trained and skilled personnel. Before use the manual should be read and followed carefully. Furthermore Trotec Produktions- u. Vertriebs GmbH reserves the right to change or alter any product described herein without prior notice.



In case of failure, please check the device first. If unsuccessful, please note all data of the device (year of manufacture, software version, etc.) and call us from a telephone next to the switched on device. For queries or technical problems please contact your dealer or Trotec Produktions- u. Vertriebs GmbH directly at the above address.



Contents

1	Introduction.....	5
1.1	Scope of SpeedMarker 1300.....	5
2	General Information	5
2.1	Operation Manual Use.....	6
2.2	Intended Use	6
2.3	Disposal Remarks.....	7
3	Technical Data	16
3.1	SpeedMarker 1300 Dimensions	16
3.1.1	Interior (Standard version).....	16
3.1.2	Interior (with software controlled Y-axis)	17
3.1.3	Exterior dimensions	18
3.2	Setup.....	19
3.3	Datasheet	20
4	EU – Declaration of Conformity	8
5	Safety	9
5.1	Laser Classification.....	9
5.2	Safety regulations	10
5.3	General Safety Information.....	10
5.3.1	Safety-conscious Working.....	10
5.3.2	Safety Information for the User and/or Operating Personnel.....	11
5.4	Laser Safety Information.....	11
5.5	Warning and Information Labels.....	12
5.6	Risks	14
5.7	Gases, Fumes and Dust.....	15
6	Transport and Installation	23
6.1	Unloading, Inspection and Reporting Faults	23
6.2	Scope of Supply (Standard Configurations)	23
6.3	Transport in Packaging Case	24
6.4	Unpack the Machine	24
6.5	Storage and Packaging	25
6.6	Transport Protection	25
6.7	Plant-internal transport (Repositioning the System).....	25
7	System Overview	26
7.1	General System Overview of SpeedMarker 1300	26
7.2	Processing Area Layout.....	29
7.2.1	SpeedMarker 1300 Software controlled Z- and X-axis	29
7.2.2	SpeedMarker 1300 Software controlled Z- X- and Y-axis.....	30
7.2.3	General axis design.....	30
7.3	Power Supply Connector.....	31
7.4	Safety Devices.....	34
7.4.1	Main Switch	34
7.4.2	Emergency Stop Device.....	35
7.4.3	Safety switches inside the safety door	36
7.4.4	Laser protection glass	36
7.4.5	Laser protection shutter.....	36
7.4.6	Cover plate	36
8	Operation.....	37

8.1	Control Elements on the Front of SpeedMarker 1300	37
8.1.1	LEDs on the Keypad	37
8.1.2	SpeedMarker 1300 Keypad	38
8.1.3	Emergency Stop and Automatic Start Button	38
8.2	Control Elements	32
8.2.1	Control Rack	32
8.2.2	Laser Rack	32
8.2.3	Industrial-PC	33
9	Commissioning	39
9.1	General Instructions	39
9.2	Installation of SpeedMarker 1300	39
9.3	Before Commissioning	39
9.4	Power On Procedure	40
9.5	Manual Mode	41
9.5.1	Safety door	41
9.5.2	Software controlled X and Z-axis (optional: Y-axis)	41
9.6	Automatic Mode	42
9.6.1	Automatic mode sequence	42
9.7	SpeedMarker 1300 Power Off Procedure	42
10	Setting up	43
10.1	Setting up the Focus	43
10.2	Positioning the Workpiece	43
11	Troubleshooting	44
11.1	Error Analysis	44
11.2	Common Errors	44
12	Maintenance	46
12.1	General Maintenance	46
12.2	Maintenance schedule	47
12.3	Cleaning the Lenses	47
12.4	Replacing the Filter Mat	48
12.5	Observation window	49
13	Disassembly	49
13.1	Sequence	49

1 Introduction

In choosing the SpeedMarker 1300, you have selected a second generation high-quality galvo laser marking system. The Yb fiber laser source means the system has an extremely **long life-cycle** and **minimal maintenance costs**.

The combination of a high quality galvo scanner and a fiber laser produce **highly precise marking results** in **short marking times**.

This, together with the marking software and the available interfaces, provides a **flexible** and **productive** marking solution of the highest quality standards.

1.1 Scope of SpeedMarker 1300

This operational manual is valid for all construction stages and different options of SpeedMarker 1300.

- SpeedMarker 1300 with Software controlled Z- and X-Axis
- SpeedMarker 1300 with Software controlled Z, X- und Y-Axis

For detailed information see chapter "Technical Data".

2 General Information

Strict compliance with the safety procedures described in this Operationmanual and exercising extreme caution when using the equipment are essential for avoiding and reducing the possibility of personal injury or damage to the equipment.

All information, illustrations, tables, specifications and diagrams contained in this Operationmanual have been carefully compiled according to the art current at the time of going to press. No liability is accepted with regard to errors, missing information and any resulting damage or consequential loss.

Trotec Produktions und Vertriebs Ges.m.b.H. reserves the right to update any of the information, illustrations, tables, specifications and diagrams contained in this Operationmanual with regard to technical developments at any time without notice.

Any software incorporated in this equipment should only be used for the purpose for which it was supplied by Trotec Produktions und Vertriebs Ges.m.b.H. It is strictly prohibited for the user to undertake any alterations, conversions, translations into another computer language or copies (except for any essential back-up copies).

Trotec Produktions und Vertriebs Ges.m.b.H. is not responsible for any personal injury or material damage, of either an indirect or specific nature, consequential loss, loss of commercial profits, interruption to business, or loss of commercial information resulting from the use of the equipment described in this manual.

2.1 Operation Manual Use



- Please read and follow this Operation Manual carefully, before installation and operation.
- Ensure the operation manual is accessible at all times.
- Damage to persons and/or material can result from not following individual points of the Operation Manual!!

Operation of the system is only permitted with equipment and spare parts supplied or listed in the spare parts and consumables lists.

The following symbols are used for easier understanding of the Operation Manual:



If the Operation Manual is not observed, this area represents a particular danger for the operating personnel or the personnel responsible for maintenance.



Caution: This component is under voltage. In these areas strictly observe the safety instructions regarding electricity. Care is to be taken in particular during maintenance and repair work.



Caution: In this area pay attention to the possible dangers of the laser beam.



Note or information on individual components of the device, that simplify the use or make it more understandable.

2.2 Intended Use

The SpeedMarker 1300 is intended exclusively for laser marking using the supplied marking software.

The following points should also be observed as part of the intended use:



- Only mark approved materials using suitable parameters
- Non-observance of the instructions for operation, maintenance and repair described in this Operation Manual excludes any liability of the manufacturer if a defect occurs..
- The system must only be operated, maintained and repaired, by personnel that are familiar with the designated field of use and the dangers of the machine!
Perform maintenance and service according to the specifications in this operation manual
- Use a suitable extraction system to remove fumes, dust or other reaction products
- Operation of the system is only permitted with equipment and spare parts supplied or listed in the spare parts and consumables lists.
- Use of the system in other areas is against the designated use. The manufacturer does not admit liability for damage to personal and/or equipment resulting from such use.



2.3 Disposal Remarks



Do not dispose the machine with domestic waste!

Electronic devices have to be disposed according to the regional directives on electronic and electric waste disposal. In case of further questions, please ask your supplier.

Use suitable tools if you have to disassembly the machine. All separate parts need to be sorted into the different material types and also be disposed according to the regional directives on electronic and electric waste disposal.

2.4 Manufacturer's Label

The Manufacturer's Label is located on the backside of the machine.

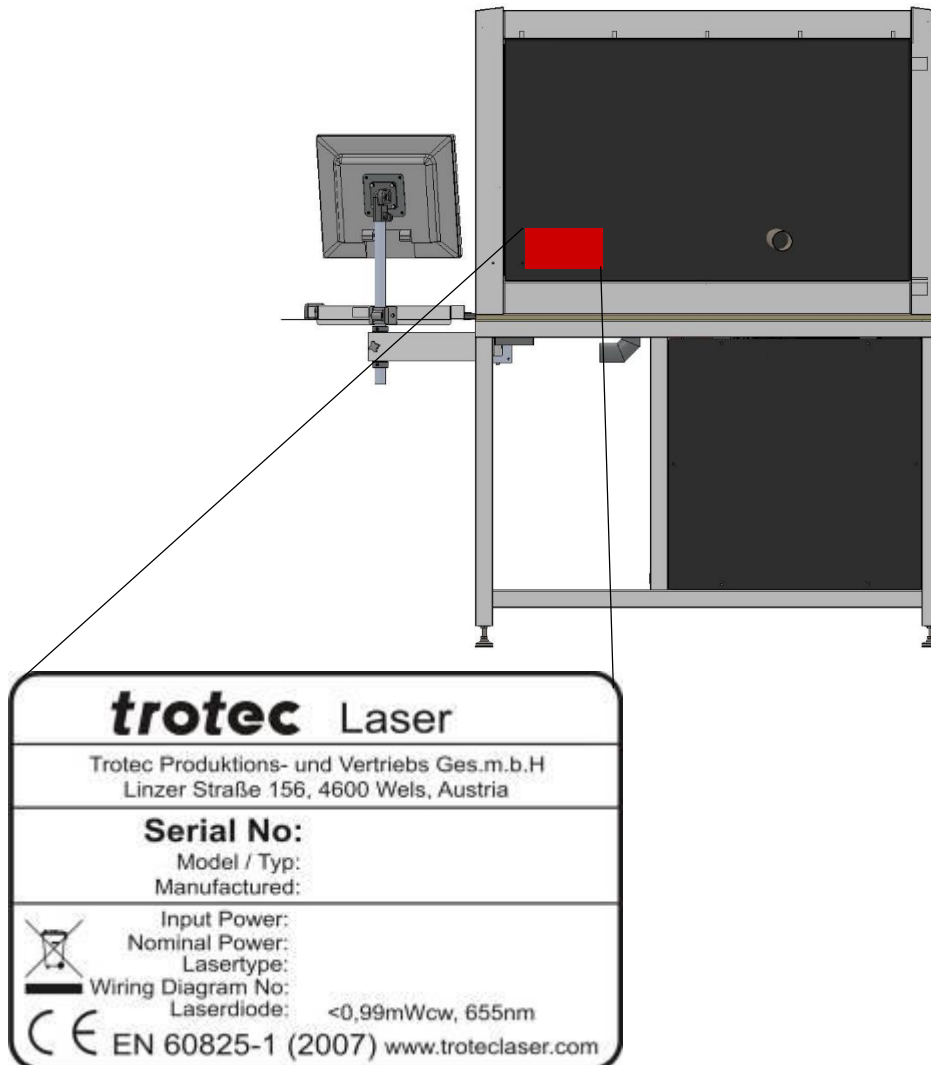

Enter the serial number, model and year of manufacture from the manufacturing label here. This information is important for troubleshooting problems and ordering replacement parts.

2.5 EU – Declaration of Conformity

EU – Declaration of conformity

for the purposes of EC machinery directive 2006/42/EC, appendix II 1. A

Maker Community resident authorised to assemble technical documents

Trotec Laser Automation GmbH	Jochen Huber
Planckstr. 12	Trotec Laser Automation GmbH
88677 Markdorf	Planckstr. 12
	88677 Markdorf

Description and identification of the machinery

Product/commodity	LWS1300-xx
Model	LWS1300
Standard number	0202
Project numberr	0202_SpeedMarker 1300
Commercial nameg	SpeedMarker 1300
ORder	0202
Function	Laser Workstation

It is expressly declared that the machinery fulfils all the relevant provisions, where appropriate, of the following EC directives.

2006/42/EG	Directive 2006/42/EC of the European Parliament and of the Council of 17 May 2006 on machinery, and amending Directive 95/16/EC (recast) (1)
2004/108/EG	Directive 2004/108/EC of the European Parliament and of the Council of 15 December 2004 on the approximation of the laws of the Member States relating to electromagnetic compatibility and repealing Directive 89/336/EEC
2006/95/EG	Directive 2006/95/EC of the European Parliament and of the Council of 12 December 2006 on the harmonisation of the laws of Member States relating to electrical equipment designed for use within certain voltage limits (codified version) (1)

References of the harmonised standards applied in compliance with article 7 paragraph 2

EN 60825-1:2007	Safety of laser products - Part 1: Equipment classification and requirements (IEC 60825-1:2007)
EN ISO 13849-1:2008	Safety of machinery - Safety-related parts of control systems - Part 1: General principles for design (ISO 13849-1:2006)
EN ISO 12100:2010-11	Safety of machinery - General principles for design - Risk assessment and risk reduction. (ISO 12100:2010)
EN 61000-6-4:2007/A1:2011	Electromagnetic compatibility (EMC). Generic standards. Emission standard for industrial environments

Markdorf, 27.11.2014

Place,date



Signature

i.A. Jochen Huber, Electric construction

3 Safety Information

3.1 Laser Classification

The laser safety class indicates the risk potential based on the level of accessible laser radiation.

The SpeedMarker 1300 is a Class 2 laser marking system as per DIN EN 60825-1 "Safety of laser products".



Class 2 (US: class II)

The accessible laser radiation of Class 2 (US: class II) laser systems does not pose any hazard for the skin. Any short-term radiation of the eyes also poses no risk due to the low level output. In the event of longer, more intensive radiation, the eye is protected by the natural lid reflex.

The SpeedMarker 1300 uses a Class 2 (US: class II) pilot laser. In order to prevent irritation of the eyes during operation, the operator should not look directly at the laser source.

Diffuse reflections of the pilot laser are entirely harmless.

Integrated laser source of the SpeedMarker 1300 is a

Speedmarker FL , Class 4 (US: class IV) laser marking system identified according to DIN EN 60825-1.



Class 4 (US: class IV)

High powered lasers (visible or invisible) considered to present potential acute hazard to the eye and skin for both direct (intrabeam) and scatter (diffused) conditions. Also have potential hazard considerations for fire (ignition) and byproduct emissions from target or process materials.

It is the responsibility of the operator of the machine to take appropriate measurements to eliminate any dangers such as fire or explosions through the laser beam.



When dealing with class 4 (US: class IV) laser follow the following precautions:

- **According to BGV B 2 „Laser Emission“ a trained laser safety officer has to be appointed to evaluate potential hazards and to ensure that appropriate control measures are implemented.**
- The laser controlled area shall be posted with appropriate warning signs or warning lamps.
- The laser controlled area shall be defined to contain the laser radiation.
- Also it must be protected against unauthorized access.
- The operator of class 4 laser systems always has to wear appropriate safety glasses.
- An indicator (typically a light) to provide a warning of laser emission in advance of and during the emission time;



3.2 Safety regulations

The following directives and ordinances must be observed to avoid hazards when operating TROTEC laser systems.

- EN 60825-1 Safety of Laser Products - Part 1: Equipment Classification, Requirements and User's Guide
- EN 60950 Safety of Information Technology Equipment
- EN 61010-1 Safety Requirements for Electrical Equipment for Measurement, Control and Laboratory Use; General Requirements
- BGV B2 (VBG93) Laser beam
- UL 60950 Standard for Safety for Information Technology Equipment
- UL 31011-1 Electrical Equipment for Laboratory Use - Part 1: General
- 21 CFR 1040.10 Performance Standard for Light Emitting Products - Specific Laser Products
- 21 CFR 1040.11 Performance Standard for Light Emitting Products - Specific Purpose Laser Products



The general ordinances and directives listed above may differ according to locality, region or country. Therefore, always observe the directives applicable to you.

The customer is always responsible for carrying out all safety requirements as TROTEC Produktions und Vertriebs Ges.m.b.H. has no influence over the proper use of the machine.

The system integrator is responsible for observing the directives listed above when integrating our laser systems

3.3 General Safety Information



All personnel involved in installation, set-up, operation maintenance and repair of the machine, must have read and understood the Operation Manual and in particular the "Safety" section. The user is recommended to generate company-internal instructions considering the professional qualifications of the personnel employed in each case, and the receipt of the instruction/Operation Manual or the participation at introduction/training should be acknowledged in writing in each case.

3.3.1 Safety-Conscious Working



- The machine must only be operated by trained and authorized personnel.
- The scopes of competence for the different activities in the scope of operating the machine must be clearly defined and observed, so that under the aspect of safety no unclear questions of competence occur. This applies in particular to activities on the electric equipment, which must only be performed by special experts.
- For all activities concerning installation, set-up, start-up, operation, modifications of conditions and methods of operation, maintenance, inspection and repair, the switch-off procedures that may be provided in the Operation Manual must be observed.



3.3.2 Safety Information for the User and/or Operating Personnel



- No working methods are permitted that affect the safety of the machine.
- The operator must also ensure that no unauthorized persons work with the machine (e.g. by activating equipment without authorization).
- It is the duty of the operator, to check the machine before start of work for externally visible damage and defects, and to immediately report changes that appear (including behavior during operation) that affect the safety.
- The user must provide that the machine is only operated in perfect condition.
- The user must guarantee the cleanness and accessibility at and around the machine by corresponding instructions and controls.
- Principally, no safety components may be removed or disabled (already here we emphasize the imminent dangers, for example severe burns, loss of eye-sight). If the removal of safety components is required during repair and service, the replacement of the safety components must be performed immediately after completion of the service and repair activities.
- Preparation, retooling, change of work piece, maintenance and repair activities must only be performed with equipment switched off, by trained personnel.
- It is forbidden to perform unauthorized modifications and changes to the machine. It is emphasized, that any unauthorized modifications to the machine are not permitted for safety reasons.

3.4 Laser Safety Information



- Without safety precautions, the following risks exist with exposure to laser radiation:
 - Eyes: Burns to the retina for **NIR (Near Infra Red) LASER**
 - Skin: Burns
 - Clothing: Danger of fire
- The laser beam must never be directed onto persons or animal!
- Never try to modify or remove the safety devices or cover of the laser head!
- Never try to modify or disassemble the laser and do not try to start up a system that had been modified or disassembled
- **Dangerous radiation exposure can result from the use of operation or adjustment equipment other than that described here, and if different operational methods are performed.**

3.5 Warning and Information Labels



The warning and information labels are attached in such positions of the machine that could represent a source of danger during set-up and operation. Therefore, follow the information on the labels. If labels are lost or damaged, they must be replaced immediately

Front View

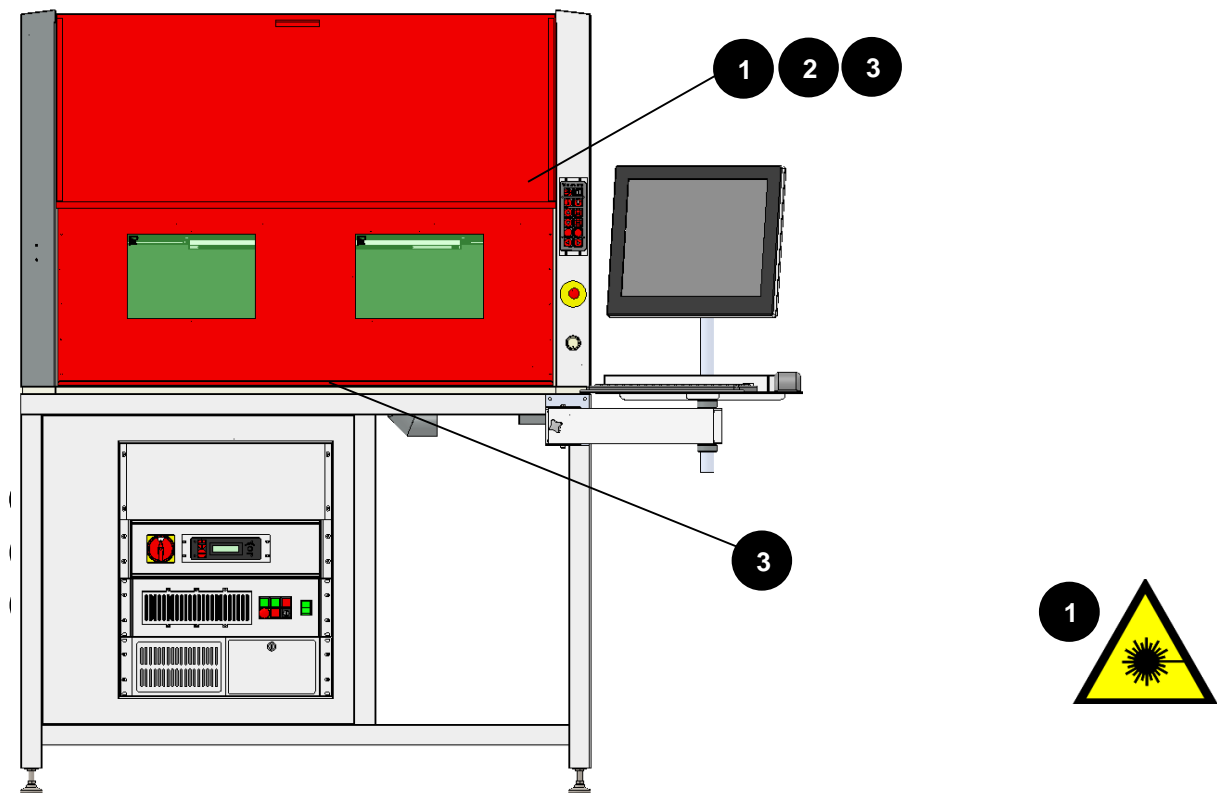

2

YTTERBIUM FIBER LASER
 $P_0 < 60 \text{ W}$, $P_p < 30 \text{ kW}$, $E_p < 2 \text{ mJ}$
 $\lambda = 1050 \dots 1200 \text{ nm}$
LASERPOINTER
 $P_{\text{max}} < 0,99 \text{ mW cw}$, $\lambda = 655 \text{ nm}$

3

CAUTION
 VISIBLE AND INVISIBLE LASER RADIATION
CLASS 4, WHEN OPENED AND
 SAFETY INTERLOCKS DEFEATED
 AVOID EYE OR SKIN EXPOSURE TO
 DIRECT OR SCATTERED RADIATION

4

CAUTION
 VISIBLE LASER RADIATION
CLASS 2, WHEN OPENED
 DO NOT STARE INTO BEAM

5

**NEVER OPERATE THE LASER SYSTEM
 WITHOUT CONSTANT SUPERVISION**
 EXPOSURE TO THE LASER BEAM MAY
 CAUSE IGNITION OF COMBUSTIBLE
 MATERIALS WHICH CAN CAUSE SEVERE
 DAMAGE TO THE EQUIPMENT

Right Side View

Left Side View

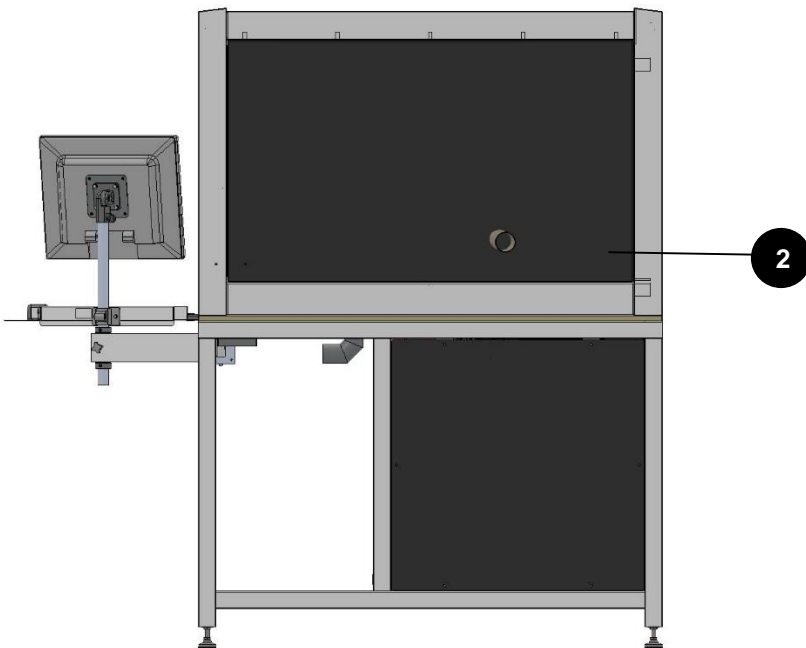
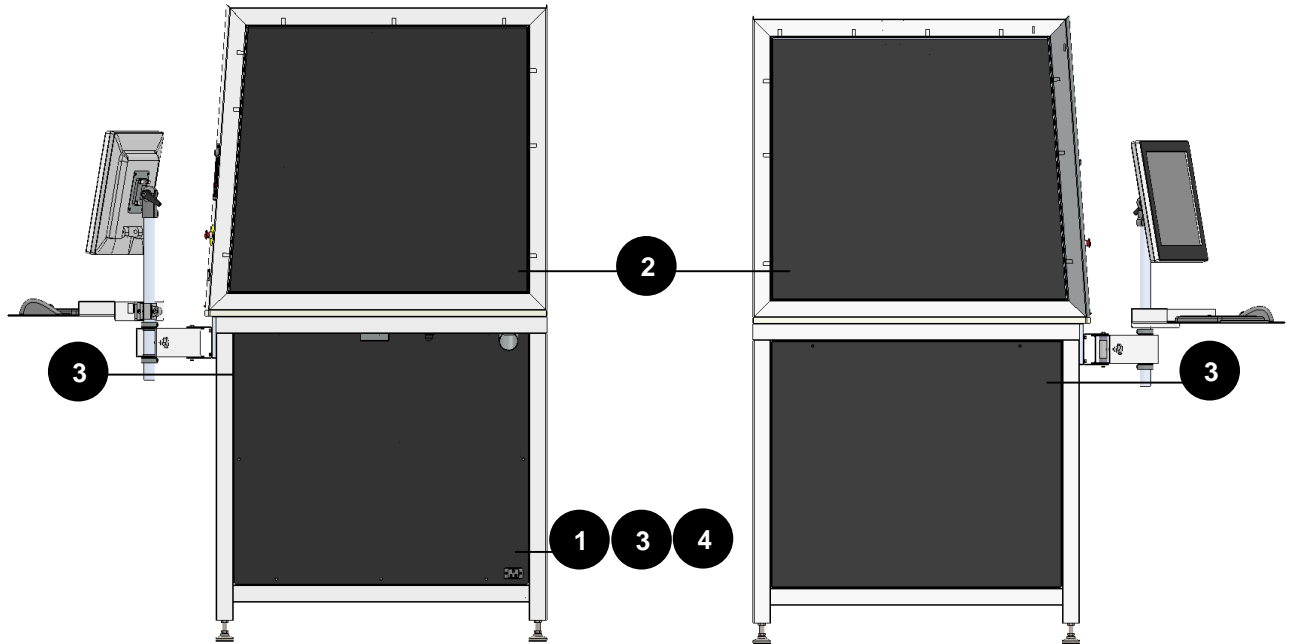

2

CAUTION
VISIBLE AND INVISIBLE LASER RADIATION
CLASS 4, WHEN OPENED
AVOID EYE OR SKIN EXPOSURE TO
DIRECT OR SCATTERED RADIATION

3

HAZARDOUS VOLTAGE INSIDE
DISCONNECT POWER BEFORE OPENING

4

INPUT POWER
100-240VAC 50/60Hz

3.6 Risks



Risk posed by the incorrect actions of untrained individuals!

The improper use of the machine can lead to injury and/or damage to the machine.

→ Inform personnel about the machine's function and any other risks and record this in the training records.

Observe official regulations regarding the operation of machines and accident prevention regulations



Risk posed by missing, faulty or bridged safety installations and machine components!

Faulty or missing safety installations and machine components can lead to death, injury and/or damage to the machine.

→ Check carefully that safety installations and machine components are functioning properly and are fault free.

→ The specified actions should be undertaken immediately if parts are faulty or defective.



Risk posed by incorrect operation (in particular in setup-mode)!

Setting and operating the machine with limited knowledge of its function can lead to injury and/or damage to the machine.

→ Read and observe the operating and safety instructions before commissioning the machine!



Risk posed by incorrect operation by unauthorised individuals!

Setting and operating the machine with limited knowledge of its function can lead to injury and/or damage to the machine.

→ Never leave the machine unattended while in operation.

→ Turn off the machine at the main switch when not in use.



Risk posed by missing machine signage!

Making the wrong assumptions can lead to the risk that the machine is operated incorrectly.

→ Replace missing machine signage.



Risk posed by non-repairable faults!

Any non-repairable fault may damage the machine.

→ Turn off the machine and call customer service!





Risk posed by using inferior spare parts or parts of other manufacturers!

The use of inferior spare parts or parts produced by other manufacturers impairs the safety of the machine and invalidates the Declaration of Conformity (CE) supplied with it.

- Wear parts or damaged mechanical, safety or electrical components should be replaced by original spare parts.



Risk posed by missing protective equipment!

- Wear the appropriate workwear.
- Wear safety glasses (**class 4/USA: Class IV**)
- Use a suitable extraction system.



Risk posed by laser marking reaction products!

A suitable extraction system must be used when laser marking due to the possible generation of gases, fumes and any other partially toxic by-product.

In individual cases, the reaction products may consist of static dust. If this enters any electrical systems it can cause short circuits leading to personal injury and material damage.



Risk posed by flammable or explosive materials!

Class 4 laser radiation such as that emitted by the SpeedMarker 1300 may ignite materials or cause explosions. Among others it should be ensured that:

- Parameters are selected so that the material does not overheat
- The system is monitored if necessary
- Dust is extracted safely

There is no accumulation of any flammable residues or remnants in the workspace.

3.7 Gases, Fumes and Dust

Depending on the materials being marked and the parameters selected, laser marking may generate gases, fumes, aerosols or dust.

The toxicity of such by-products depends on the material.

The operator is responsible for ensuring a suitable extraction system is in place and for compliance with the relevant guidelines in order to protect individuals and the environment.

The guideline VDI 2262 1...3 "Workplace air " provides, among other things, additional remarks.

The operator must also ensure that gases, fumes or dust do not settle on the processing lens. Any dirt accumulating on the processing lens can lead to a loss of performance, poor marking results and damage to the device.



4 Technical Data

4.1 SpeedMarker 1300 Dimensions

4.1.1 Interior (Standard version)

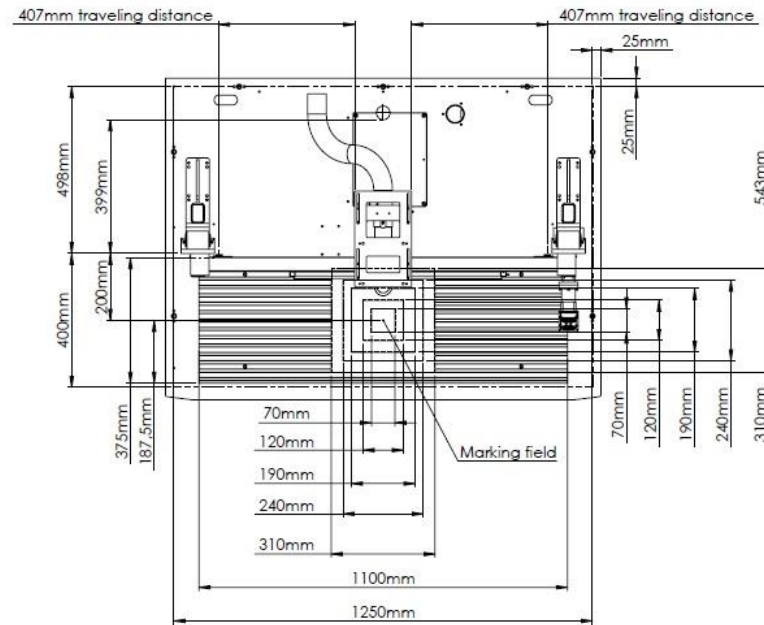

Figure 1: Top view

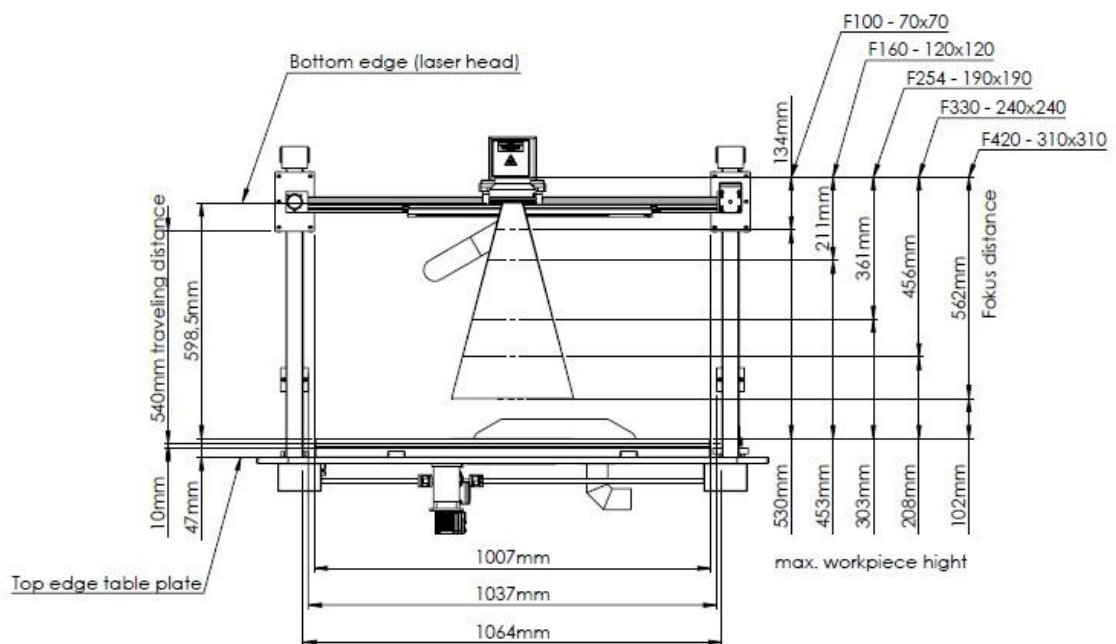

Figure 2: Front view

4.1.2 Interior (with software controlled Y-axis)

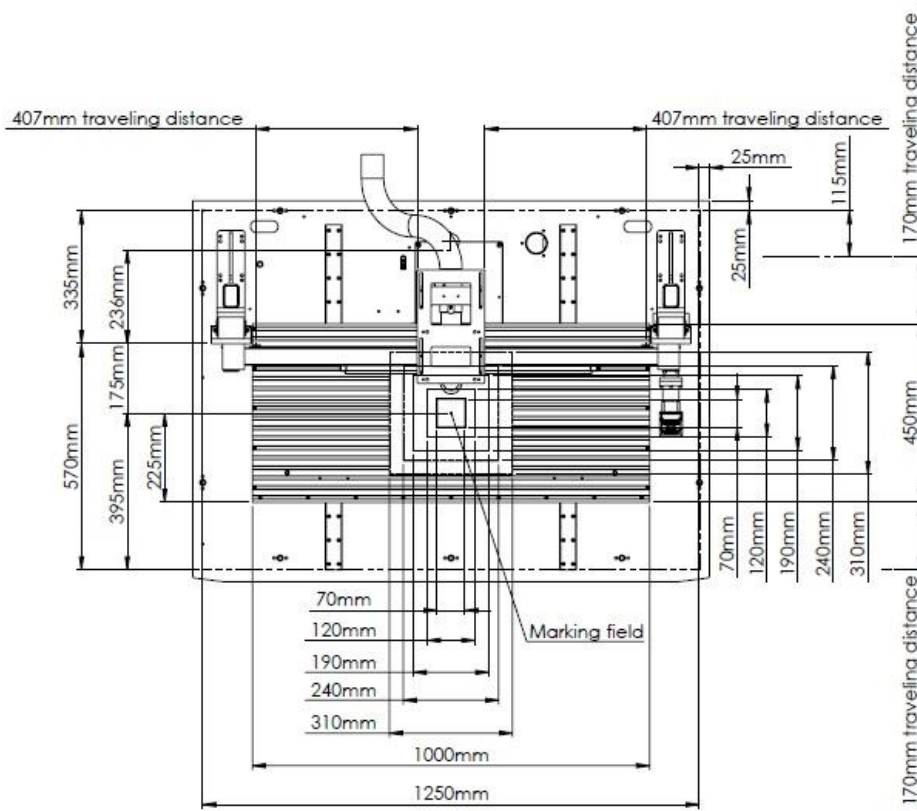

Figure 3. Top view with Y-axis

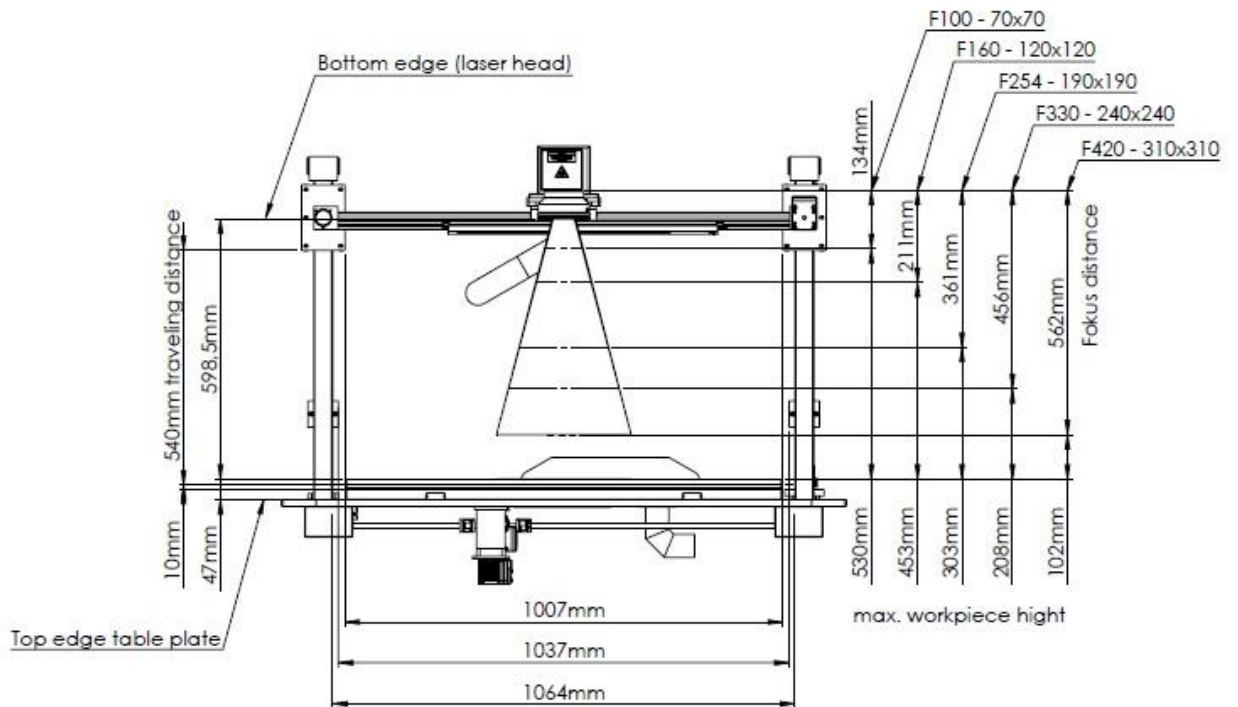

Figure 4: Front view with Y-axis

4.1.3 Exterior dimensions

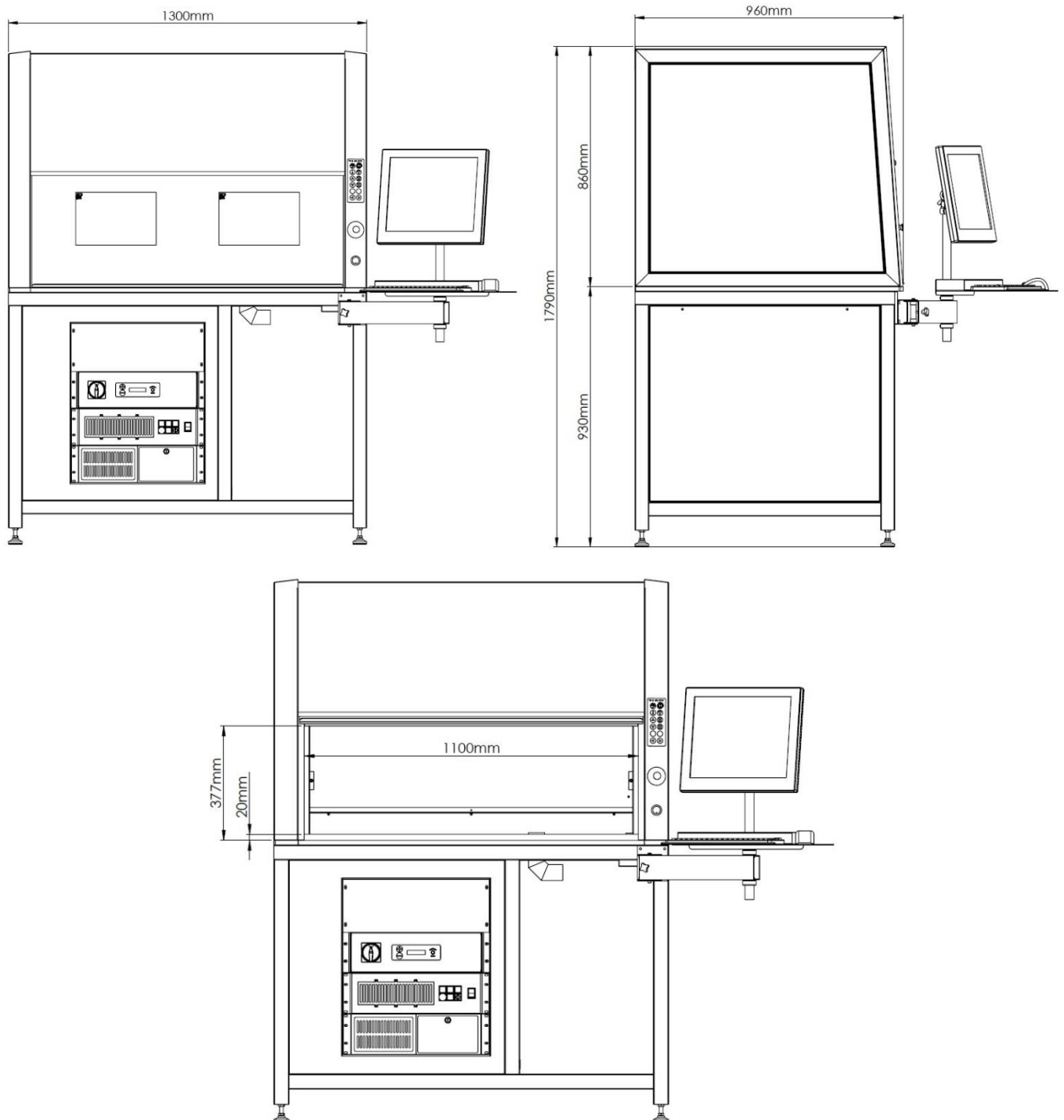

Figure 5: Front and side view

4.2 Setup

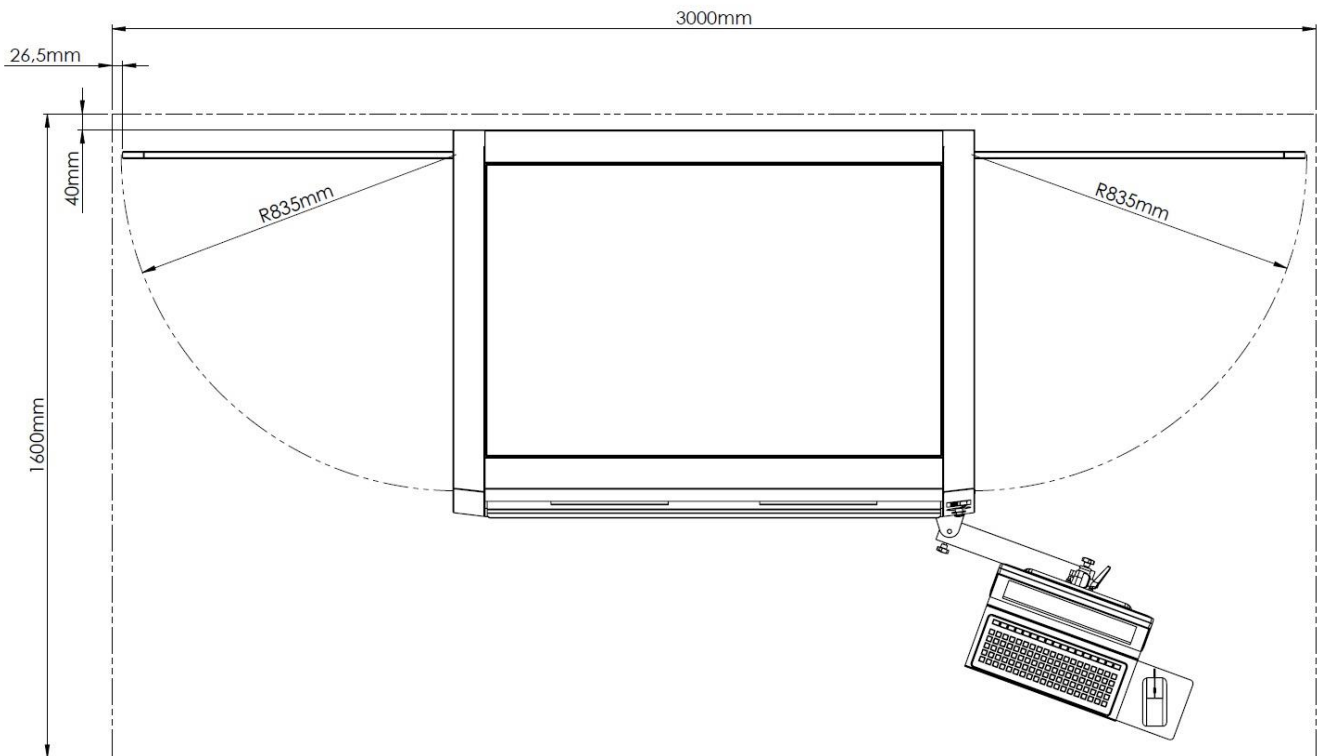

Figure 6: Setup

4.3 Datasheet

Laser (Fiber Laser)				
Laser	Q-Switched Yb-Fiber Laser, maintenance free			
Wavelength	1064 nm ± 8			
Pulse Duration	110 ns ± 20			
Beam Quality	M ² < 1,5			
Power stability	better ± 5%			
Cooling	Air cooled			
Laser type	FL 10	FL 20	FL 30	FL 50
Max. average output power	10 W	20 W	30 W	50 W
Max. Pulse Energy	0,5 mJ	1 mJ	1 mJ	1 mJ
Pulse Repetition Rate	20-80 kHz	20-80 kHz	30-80 kHz	50-80 kHz
Integrated Pilot Laser	✓	✓	✓	✓

Galvo System					
Lens / Focal length	F-100	Stand- ard: F-160	F-254	F-330	F-420
Marking area [mm x mm]	70 x 70	120 x 120	190 x 190	240 x 240	310 x 310
Focus Diameter	~ 27 µm	~ 45 µm	~ 68 µm	~ 88 µm	~ 112 µm
Writing Speed (Option high speed scan head)	640 cps – 1 mm single line with F = 160 mm (900 cps – 1 mm single line with F = 160 mm)				
Positioning Speed (Option high speed scan head)	10.000 mm/s with F = 160 mm (15.000 mm/s with F = 160 mm)				

Workstation					
Interior dimensions (W x D)	1250 x 898 mm ²				
Door opening (W x H)	1100 x 377 mm ²				
Door	Manual and/or automatic				
Maximum part size (W x D)	S. drawings – depends on shape				
Maximum part height* Depends on lens *27 mm less with optional Y-axis	557 mm F-100	480 mm F-160	330 mm F-254	235 mm F-330	129 mm F-420
Maximum load	200 kg (50kg with y-axis)				
Working table	Aluminum T-slot plate (Isel PT 25): 1100 x 375 mm ² 1000 x 450 mm ² with software controlled Y-axis				
Axis	Software controlled Z- and X-axis: standard Y-axis: optional				
Traveling distance Z-axis	530 mm				
Traveling distance X-axis	810 mm				
Traveling distance Y-axis	325 mm				
Maximum marking field with X-axis [W x D in mm]	880 x 70	930 x 120	1010 x 190	1050 x 240	1120 x 310
Maximum marking field with X- and Y-axis* [W x D in mm] *Option	880 x 395	930 x 445	1010 x 515	1050 x 565	1120 x 635
Color	RAL 3002, RAL 7016, RAL 7035				

Tolerance on dimension: 1%

Control	
Computer	Industrial PC as 19" Rack Unit, 3RU high, 4 GB RAM, HDD 250 GB, DVD ROM, Windows® 7
Interfaces	USB, Ethernet, RS232,
Interfaces Laser	Laser-Interlock, Marking-Start (24 VDC), Marking-Stop (24 VDC), E-Stop, Error-Reset, Laser-Busy, optional digital I/O's (24 VDC),
Software	SpeedMark

Options / Accessories	
Optional lenses and galvo scanners	F-100, F-160, F-254, F-330, F-420 High speed scan heads with lenses <i>(no F-420 lens in combination with high speed scanner)</i>
Axis system	Software controlled Y-axis
Focus Finder	Second pilot laser for precise and user friendly adjustment of working distance
Software	DirectMark printer driver: Laser marking as easy as printing. Independent from software
Extended I/O interface	Additional in- and outputs, 24 VDC
Additional optional accessories	<ul style="list-style-type: none"> • Rotary unit with different chucks • Counter bearing for rotary unit • Base plate for rotary unit • Foot switch for efficient and user friendly control of the system • Exhaust systems • Transport reels

Dimensions / Installation / Laser Safety	
Dimensions (W x H x D)	1300 x 1790 x 960 mm ³
Weight (with Laser)	380 kg <i>(400 kg with Y-axis)</i>
Ambient conditions	Operating temperature range +5 to +35° C. Relative humidity max. 90 %; Non-Condensing
Electrical Requirements	115 - 230 VAC, 16 A, 50/60 Hz, 1/N/PE
Power Consumption	< 1100 W
System Protection	Marking Head: sealed against spray water <i>(IP 54)</i> Laser Rack Unit: dust protected <i>(IP20)</i>
Laser class	CDRH Laser Safety Laser Class 2 CE tested

5 Transport and Installation

5.1 Unloading, Inspection and Reporting Faults

After unloading:

- Inspect the machine and machine components for transportation damage.
- Check screws and screw joints
- Check the delivery for completeness.
- Remove all transport packaging.

In the event of transportation damage or incomplete delivery:

- Record all details in writing immediately.
- Note all claims on the transportation documents.
- Photograph any damage.
- Send report to TROTEC.



CAUTION

The lens unit should only be uncovered following installation. The lenses are high quality optical components which must be kept clean in order to ensure optimum marking results.

Never touch the lenses with bare fingers!

5.2 Scope of Supply (Standard Configurations)

- 1x SpeedMarker 1300
- 2x key for SpeedMarker 1300
- 2x key for Industrial PC
- 2x key for laser rack
- 1x CD with marking software
- 1x CD with Windows Backup
- 1x lens cleaning kits
- 1x Allen key set
- 1x IEC connector
- 1x extraction system connection cable (optional)



5.3 Transport in Packaging Case

The System may only be transported in the original packaging and must be secured against slippage and tipping. The packaging case . Unload the transport case with a suitable forklift.



CAUTION

During transport the transport case can slip, tip or fall over. Always secure the transport case and take into account the center of gravity of the box.



5.4 Unpack the Machine

Only trained and authorised personned are permitted to tranport and unpack the machine.

To avoid that any wooden parts are falling off or the machine is tipping, be very careful when opening the transport case. Two persons are needed to unpack the machine.

- Position the transport case on level ground.
- Remove the vertical tightening straps.
- Remove the top of the transport case.



5.5 Storage and Packaging

The storage location must be free of caustic materials, vapors and combustible materials. In storage room or packaged with adequate weather protection.

Storage conditions:

- Storage temperature: +0 bis +40°C (+0 to 104°F)
- Relative humidity: max. 85%

5.6 Transport Protection

Once the SpeedMarker 1300 has been unpacked from the wooden packaging, remove the plastic foam from the front of the machine and at the door mechanism. Foam might be placed above and below the door weight.

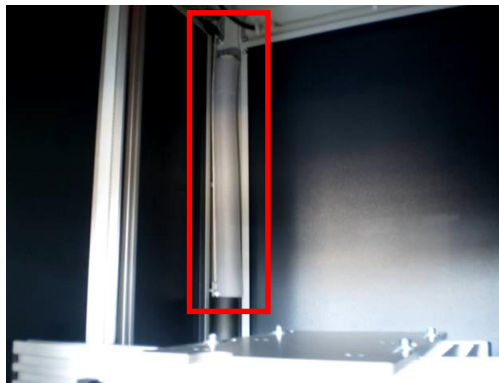

Interior protection on the door mechanism

5.7 Plant-internal transport (Repositioning the System)

The LWS needs to be transported in an upright position; avoid any strong vibrations.

1. Shut off the machine using the main switch.
2. Unplug the electrical supply.
3. Remove the exhaust system.
4. Use an appropriate fork lift to slightly lift the System,
5. Reposition and
6. Park the System on clean, solid level ground again.
7. Adjust the machine, setup the electrics and carry out a performance test.



CAUTION

When transporting the System over great distances the original transport box including interior protection needs to be used.



6 System Overview

6.1 General System Overview of SpeedMarker 1300

It consists of the the following components and functional units.

Front view:

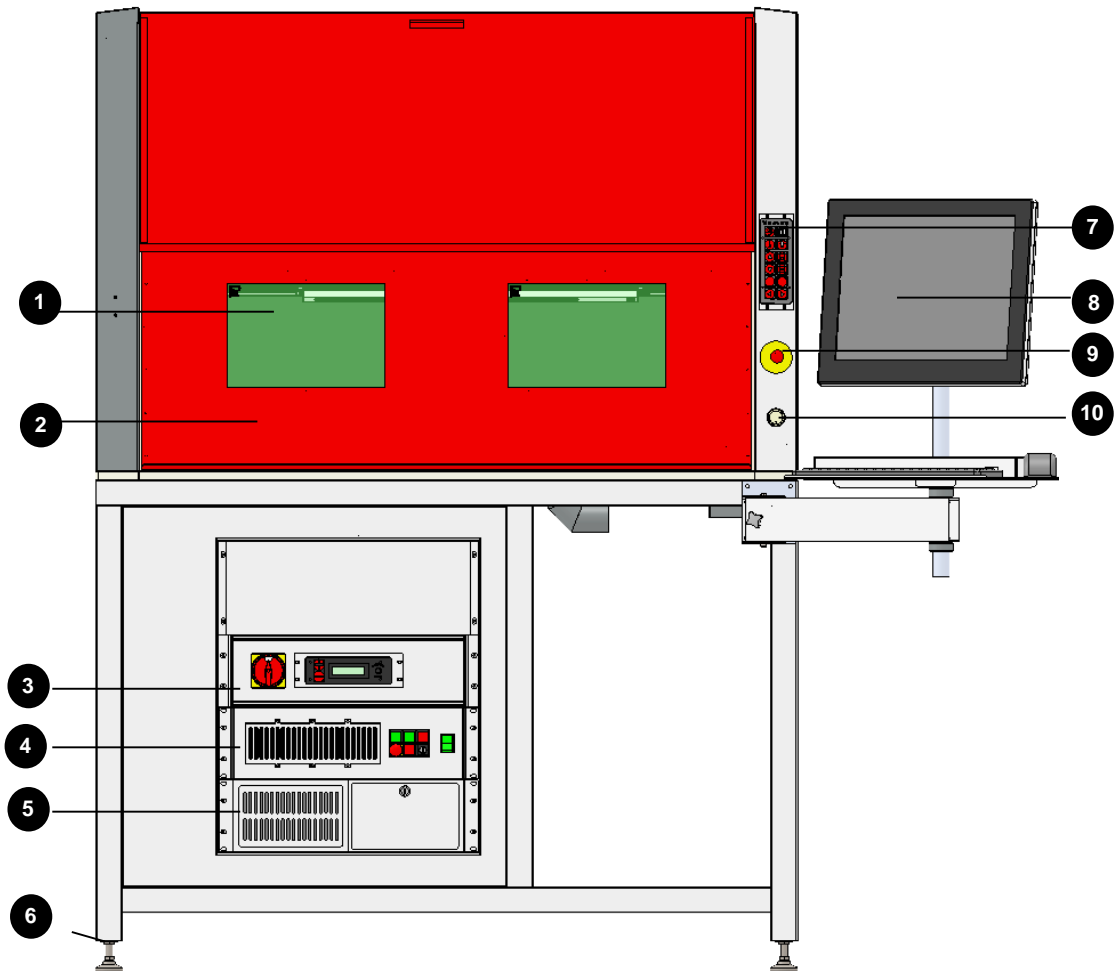

1	Safety glass	6	Feet
2	Safety door	7	Keypad
3	Control Rack	8	Monitor, keyboard and mouse
4	Laser Rack	9	Emergency Stop button
5	Industrial-PC	10	Start button

Right hand side:

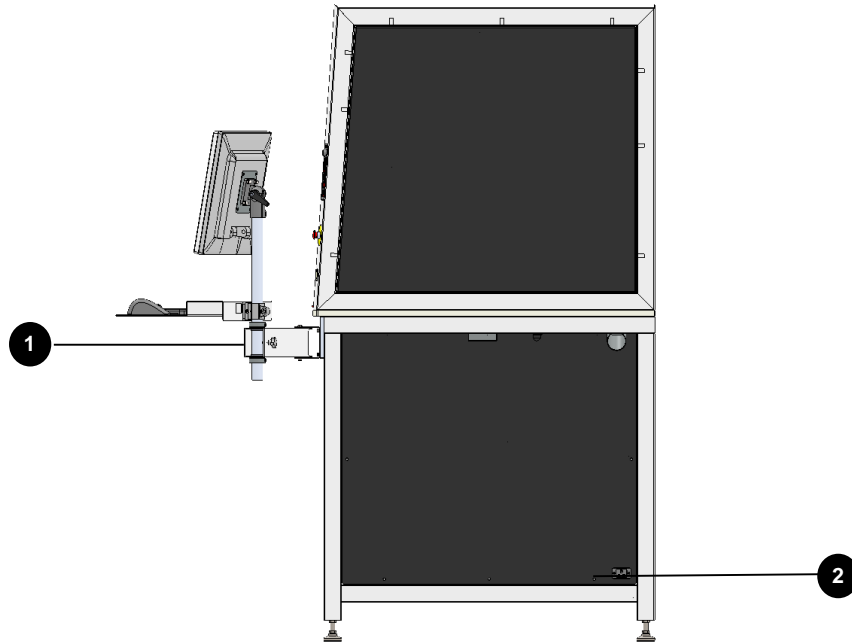

1 Swivel arm	2 Power supply connector
---------------------	---------------------------------

Left hand side:

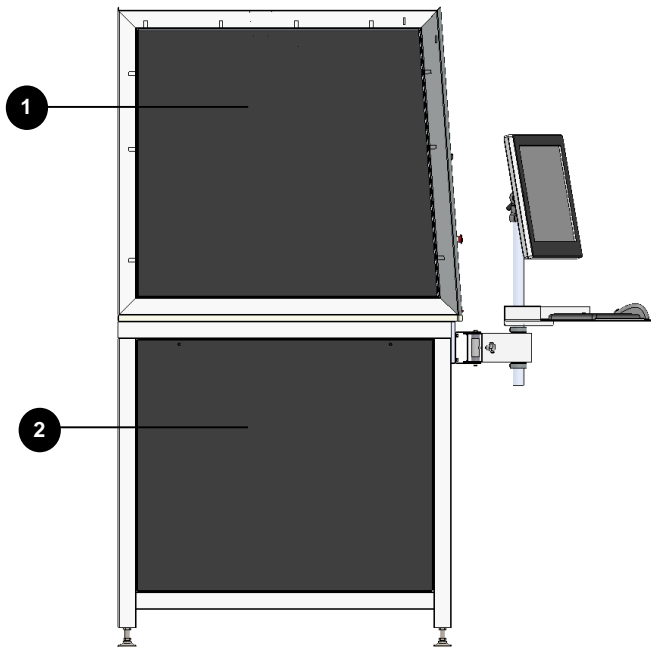

1 Protection cover	2 Cover
---------------------------	----------------

Rear view:

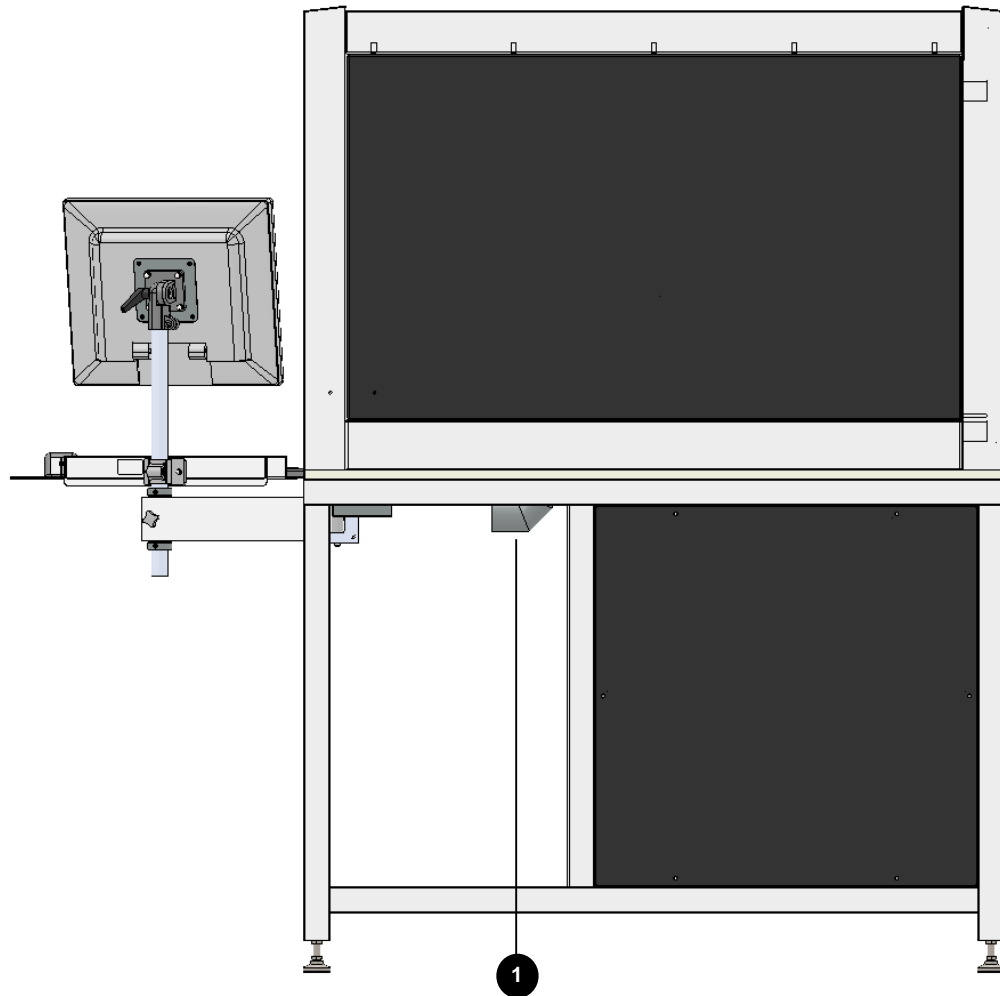

1 Extraction system connector

6.2 Processing Area Layout

The processing area contains the axis system. The processing area is closed during the marking process.

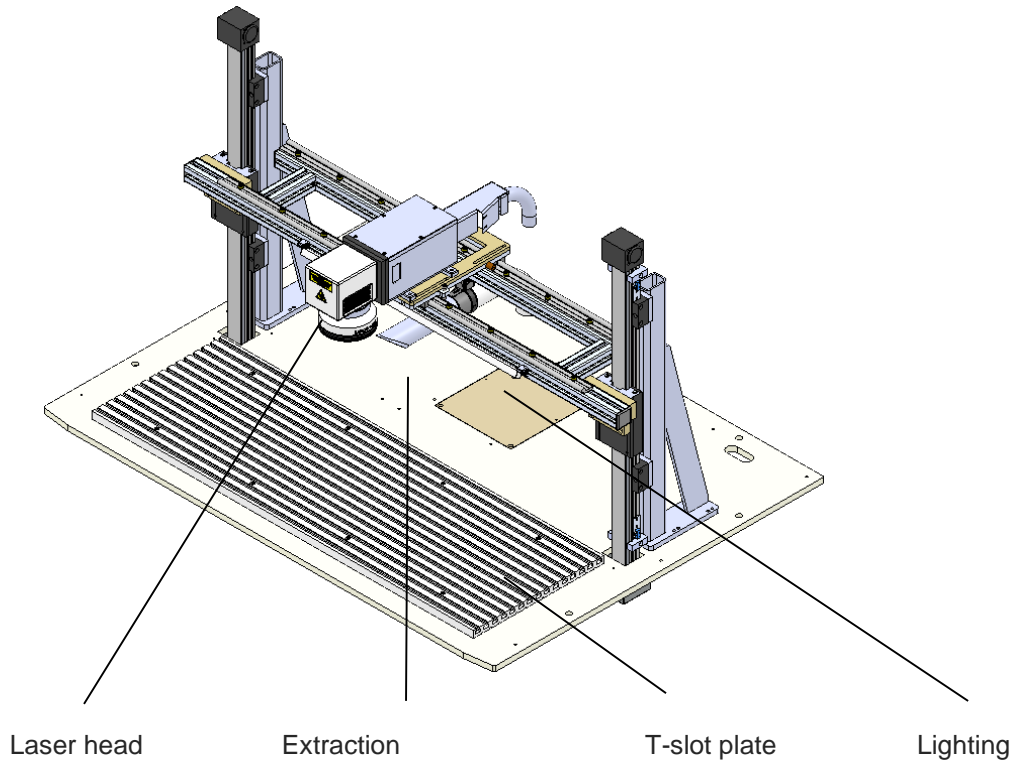

6.2.1 SpeedMarker 1300 Software controlled Z- and X-axis

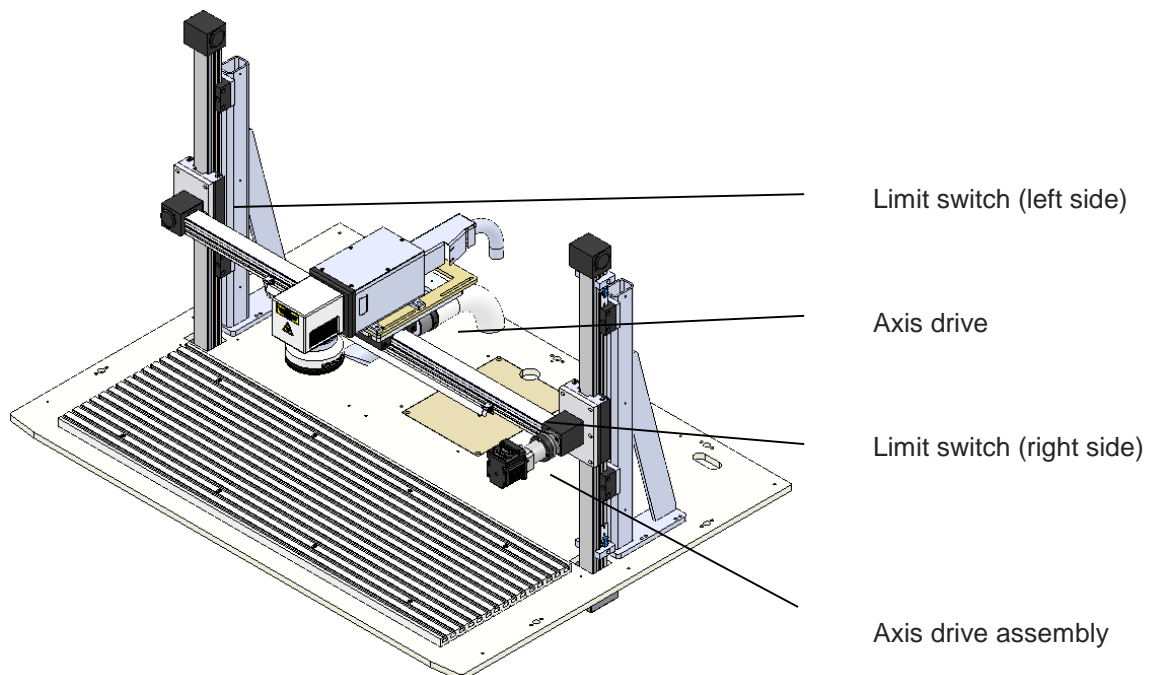

6.2.2 SpeedMarker 1300 Software controlled Z- X- and Y-axis

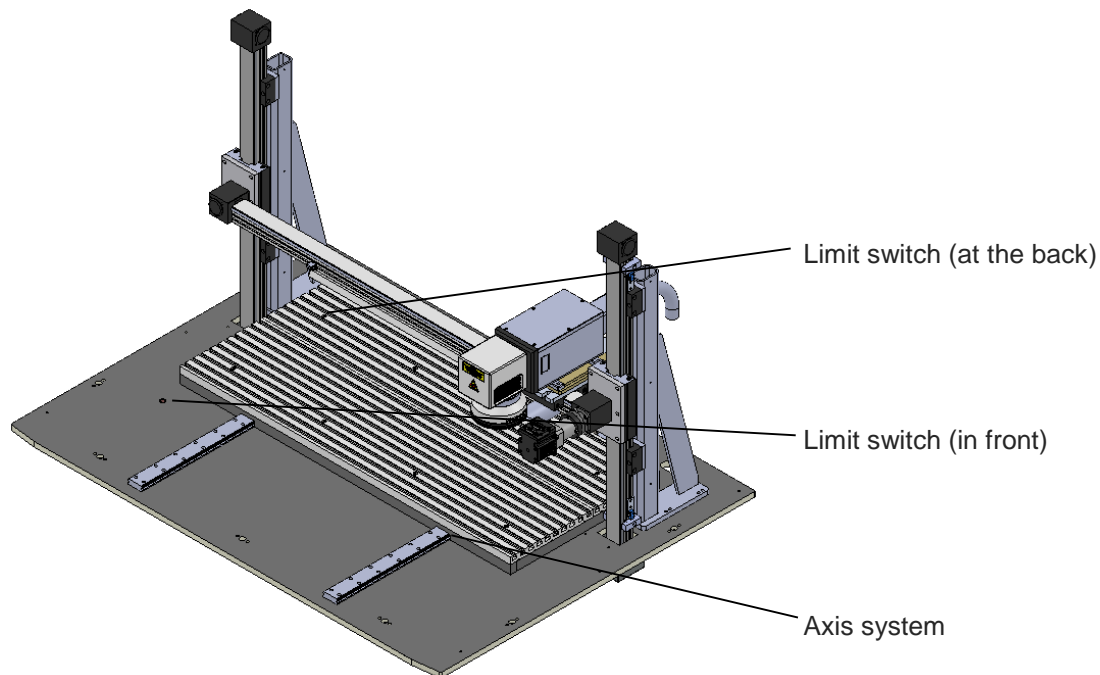

6.2.3 General axis design

Each axis system consists of a linear servo axis with precision.

Z- and Y-axis with tandem-axis and the X-axis have two limit switches and two mechanical stops.

The laser head is mounted above the adapter plate on the X-axis. The X-axis is mounted on the Z-axis.

The Y-axis is a movable table where objects can be placed.

6.3 Power Supply Connector

The power supply connector is at the rear of the SpeedMarker 1300

The air assist hose (with 40mm) can be connected.

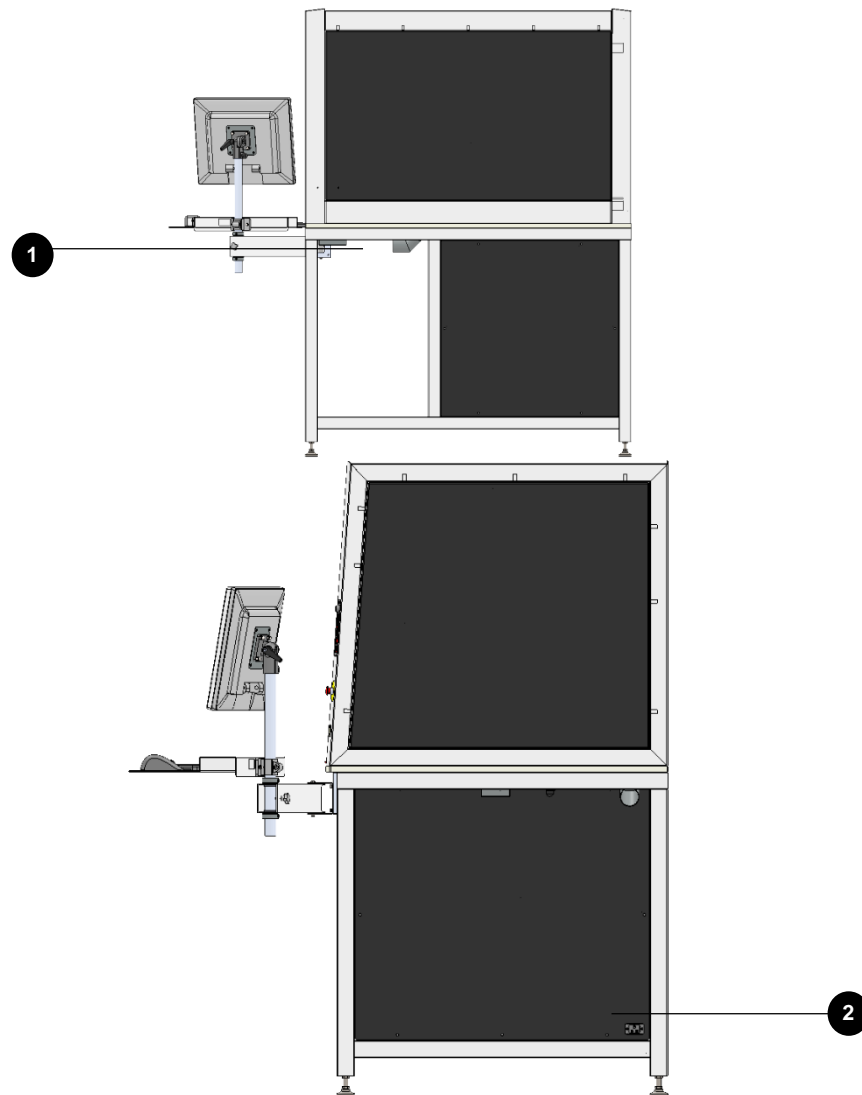

1 Extraction system connector

2 Power supply connector

6.4 Control Elements

The control elements consist of:

- Control Rack
- Laser Rack
- Industrial-PC

6.4.1 Control Rack

The control module controls the safety door, automatic mode,...

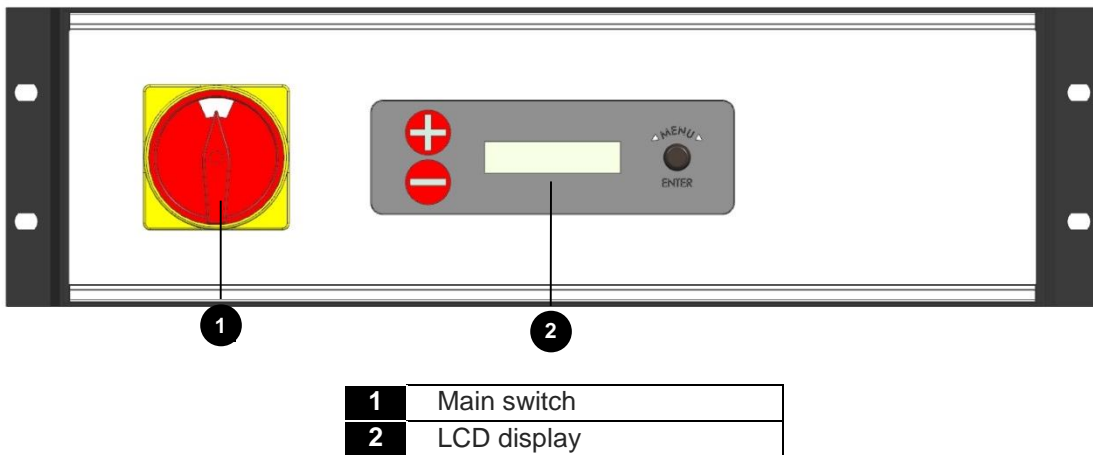

6.4.2 Laser Rack

The laser rack controls the laser head and laser rack.

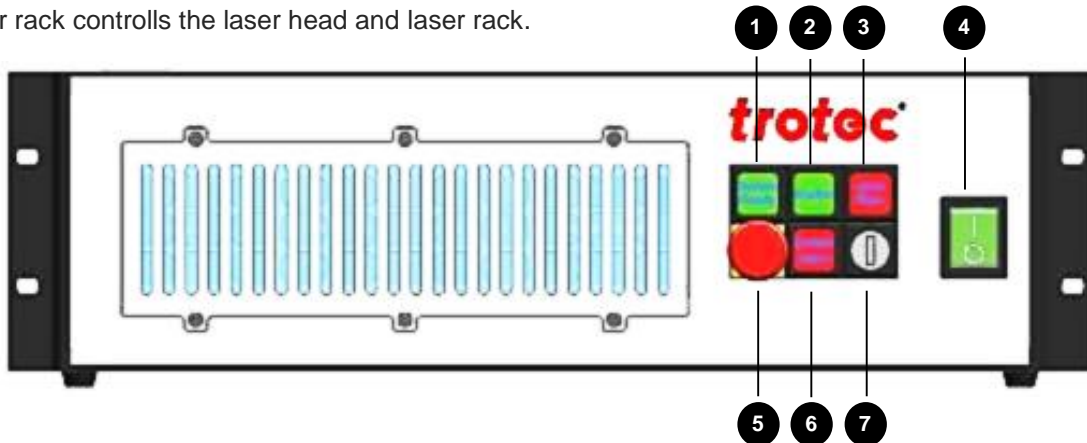

1	System ready	Control lamp
2	Shutter	Control lamp
3	Laser busy	Control lamp
4	Main laser switch	
5	EMERGENCY STOP	Switch
6	System Alarm	Button
7	Key switch	

6.4.3 Industrial-PC

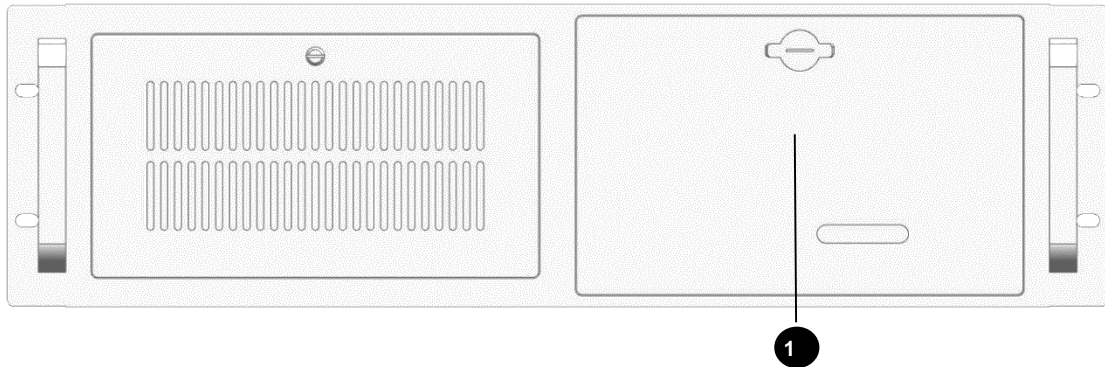

1	PC protective cover	
----------	---------------------	--

6.5 Safety Devices

The SpeedMarker 1300 is fitted with the following safety devices:

- Main switch
- Emergency stop button
- Safety switches on the safety doors
- Observation window of laser protection glass
- Laser protection shutter
- Cover plates



Do not alter or deactivate the safety switches or protective covers on the laser head or the machine.

All safety and protection devices must be installed and fully functional every time the machine is put into operation.

6.5.1 Main Switch

The main switch is situated at the system control unit at the lower part of the machine.

With the main switch the entire machine but also the laser get switched off

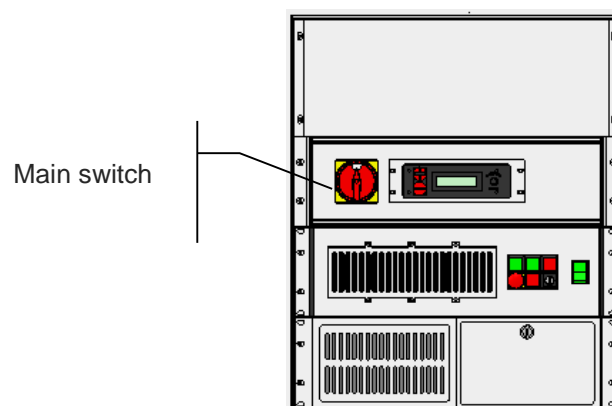

6.5.2 Emergency Stop Device

There is one emergency stop button located on the front of the SpeedMarker 1300 and a second emergency stop button on the laser module.

The function of the emergency stop device is

- Firstly: to prevent any risks to the operating personnel.
- Secondly: to avoid any damage to/destruction of the machine/material.

The emergency stop automatically shuts off the electric circuit. The laser beam is interrupted by the shutter. All movements are stopped. When the emergency stop function is triggered, an error message is displayed.

6.5.2.1 Emergency stop acknowledgement - Steps

1. Unlock the emergency stop button	Press the "Emergency stop" button	
2. Acknowledge the emergency stop error message	Press the "ON" button on the keypad	
3. Acknowledge the laser error message	Press the "ON" button on the keypad	
	OR: Press the "System alarm" button on the laser rack module	

6.5.3 Safety switches inside the safety door

The monitoring to determine whether a safety guard is open or closed is performed by two protective switches. The marking process can not be started when the safety doors are open. However the pilot laser stays active.

6.5.4 Laser protection glass

The light green observation window in the front door is made of laser protection glass in accordance with DIN EN 201. The glass consists of a special material depending on the type of laser used and which absorbs the laser radiation. The glass should be replaced if it becomes damaged.

6.5.5 Laser protection shutter

If a safety circuit in the laser cell is open, the laser protection shutter shuts momentarily. For reasons of safety this disconnection functions via safe components. The laser is interrupted mechanically. An error message is issued.

6.5.6 Cover plate

Cover plates protect from laser light.



ATTENTION

All protection plates must be mounted all times.



7 Operation

7.1 Control Elements on the Front of SpeedMarker 1300

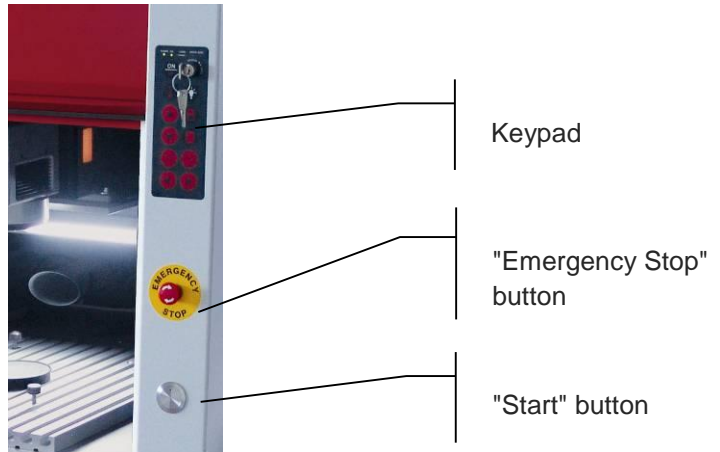

7.1.1 LEDs on the Keypad

The LEDs on the control panel have the following meanings:



Power	The SpeedMarker 1300 power supply is switched on
ON	The SpeedMarker 1300 control mechanism is switched on
Laser – Laser	The laser marker is active
Error	There is an error which has not yet been acknowledged
Auto	Automatic mode is active

7.1.2 SpeedMarker 1300 Keypad

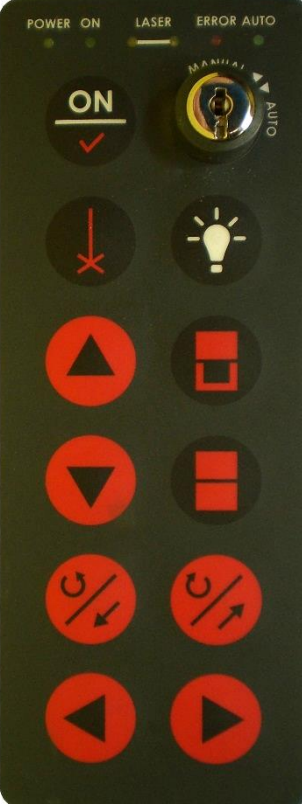
Used to acknowledge the system once it has been switched on, or after an emergency stop or fault	ON button		Key switch	Used to select either automatic or manual mode
	No function		Light	Used to switch the lighting in the processing area on or off
Used to move the Z-axis upwards	Z axis move up		Open safety door	Used to open the safety doors
Used to move the Z-axis downwards	Z axis move down		Close safety door	Used to close the safety doors
Used to move the Y-axis forwards	Y axis move forward <i>(optional)</i>		Y axis move backward <i>(optional)</i>	Used to move the Y-axis backwards
Used to move the X-axis left	X axis move left <i>(optional)</i>		X axis move right <i>(optional)</i>	Used to move the X-axis right

7.1.3 Emergency Stop and Automatic Start Button

	EMERGENCY STOP	Used to stop the SpeedMarker 1300 in an emergency (PC power supply remains uninterrupted)
	Automatic Start Button	Used to start processing in automatic mode

8 Commissioning

8.1 General Instructions



- The ambient air temperature must be between +15°C und +35°C and the relative air humidity not exceed 90% (non-condensing).
- If the system has been subject to significant temperature variations, it must be brought back to room temperature before being commissioned.
- A laser system consists of high quality electrical and optical components. Mechanical stresses, vibrations and impacts must always be avoided.
- There must be sufficient air supply to both 19" modules. The accumulation of heat due to covered ventilation slots or filter pads can damage the system.

8.2 Installation of SpeedMarker 1300



- Remove the entire packaging material.
- Remove all transport protection.
- The machine must stand upright.
- Check if the supply voltage and frequency are correct.
- Check if the power cable is intact and replace it if necessary.
- Check if the power plug is undamaged and intact.
- Before connecting the power cable to the SpeedMarker 1300 or the socket, turn the main switch on the SpeedMarker 1300 to the OFF position.
- Check if the laser protection glass is intact.

8.3 Before Commissioning

In order to ensure the unit is installed correctly, the following points should be checked:



- Check the electrical installation is complete and the input voltage is correct.
- Ensure that the optical components are free from dust and dirt.
- Have the protective covers been removed from the focusing objective lens?
- Check the environmental conditions against the technical specification.
- Are you familiar with the laser safety regulations?
- Have all laser safety measured been fulfilled?
- The system may then only be switched on once all provisions for complying with laser safety have been checked by an authorised individual and confirmed to have met the standards.



8.4 Power On Procedure

1. Switch on the SpeedMarker 1300 main switch.
2. The Industrial PC gets switched on automatically. Alternatively it can be switched on manually by pressing the button behind the protective cover.
3. Switch on the laser rack by pressing the "I/O" switch.
4. Turn the key switch on the laser rack module 90° clockwise (so it is horizontal).
5. Wait for the system to be powered up and the SpeedMark software to start..
6. Unlock the emergency stop button if necessary. See chapter "Emergency Stop Device"
7. Turn the key switch for manual or automatic mode.
8. The SpeedMarker 1300 is now ready for operation.

8.5 Manual Mode

When turning the key switch to manual mode all functions of the machine can be carried out manually. Manual mode is used to check the machine and test the marking. Marking is only possible when the safety door is closed. Please note the safety door can be opened and closed manually.

The functions are:

- Open and close the safety doors.
- Move the axis manually.
- Start the marking process.



8.5.1 Safety door

- Use the “Open safety doors” and “Close safety doors” buttons on the keypad to open and close the safety doors.

8.5.2 Software controlled X and Z-axis (optional: Y-axis)

Use the following buttons to move the axis manually:

Used to move the Z-axis upwards	Z move up		Y axis move backward <i>(optional)</i>	Used to move the Y-axis backwards	
Used to move the Z-axis downwards	Z move down		X axis move left <i>(optional)</i>	X axis move right <i>(optional)</i>	Used to move the X-axis right
Used to move the Y-axis forwards	Y axis move forward <i>(optional)</i>				

- The axis are restricted by the upper and lower limit switches.
- When travelling down- or upwards, take care that the objective does not collide with the workpiece.
- After starting the SpeedMarker 1300 or carrying out an emergency stop acknowledgement a reference run needs to be performed. Referencing can be started manually within the marking software or automatically when starting the marking software.
- In automatic mode the axis are controlled by the Industrial PC.



CAUTION

Risk of crushing when moving the axis.

8.6 Automatic Mode

When the key switch is set to auto mode all functions of the machine will be carried out automatically. Auto mode is used for an automatic production process. Marking is only possible when the safety door is closed. Please note the safety door can be opened and closed manually.

8.6.1 Automatic mode sequence



INFO

The key switch needs to be set to AUTO and the laser rack control software has booted up. .

1. Use the “Automatic Start button” to start the marking process.
2. The safety door closes.
3. The marking process is carried out automatically.
4. The safety doors open once the marking is completed.
5. Use the “Automatic Start button” to start a new marking process.



8.7 SpeedMarker 1300 Power Off Procedure

1. Stop the software on the industrial PC.
2. Shut down the laser PC operating system.
3. The SpeedMarker 1300 may be switched off using the main switch on the control rack as soon as the industrial PC operating system has been shut down.
4. Now the SpeedMarker 1300 is switched off.



9 Setting up



CAUTION

Risk of injury when working with mechanical components.

9.1 Setting up the Focus



It is absolutely essential to maintain the correct focal distance for every laser marking process. Only when in focus will the laser beam achieve the power density necessary for permanent and clearly legible marking.

Prior to any marking it is therefore necessary to set the correct focal distance between the marking head and the workpiece. An incorrect focal distance is the most common cause of poor or even indistinguishable markings.

Position the laser by moving the Z-axis until the ideal marking result has been reached.

The focal distance (**A**) is measured between the lower edge of the galvo head (**B**) and the upper surface of the workpiece (**C**). The correct focal distance depends on the lens used (focal length).

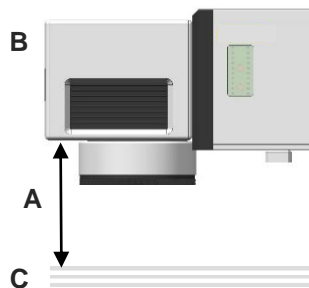

Lens	Focal distance (A)
F-100	~134,6 mm
F-160	~211,6 mm
F-254	~361,6 mm
F-330	~456,59 mm
F-420	~562,59 mm

9.2 Positioning the Workpiece

Use the “Border Mark” function in the marking software to indicate the marking field with the pilot laser.

Move the workpiece under the laser until it is in the correct marking position.



10 Troubleshooting

This chapter should assist maintenance personnel with the identification and resolution of operational faults based on error messages and symptoms.

Movements and functions may only be performed when there are no errors and all devices are ready for operation. This state is prerequisite for starting the SpeedMarker 1300. If this state changes during operation, the laser cell stops.

The error must be acknowledged using the “ON” button on the keypad.



Maintenance and repair work should only be carried out by Trotec Produktions und Vertriebs Ges.m.b.H. or one of its authorised personnel under observation of the safety regulations.

10.1 Error Analysis

If an error occurs, the “Error LED” light flashes on the keypad. The error may be read on the display.



Possible Error Messages at Control Rack	Troubleshooting
Emergency stop button	Unlock the emergency stop button and acknowledge the error
Safety door error	Start the safety door again in manual mode; if necessary, check the safety doors for heaviness/lack of movement
Output error	The electronic output of the cell control system has been overloaded; switch the main switch off and on again.

10.2 Common Errors

Problem	Possible Cause	Resolution
Not possible to turn on laser module	System switched off	Turn on main switch
	The key is missing from the key switch on the laser module or is in the vertical position.	Place the key in the switch on the laser module and turn to the horizontal position
	Emergency stop button has been activated	Release the emergency stop button
	System power plug not installed correctly	Check the System power plug has been installed correctly

Problem	Possible Cause	Resolution
Not possible to turn on laser module	Incorrect or no voltage supply to the System	Check the System 230/110V power supply
	Laser module power plug not installed correctly	Check the laser module power plug has been installed correctly
	Faulty fuse in laser power supply	Replace fuse
Not possible to turn on SpeedMarker 1300	Emergency stop button has been activated	Release the emergency stop button
	System power plug not installed correctly	Check the System power plug has been installed correctly
	Incorrect or no voltage supply to the System	Check the SpeedMarker 1300 230/110V power supply
Error message on loading the program	Plug or cable not installed correctly	Check the plug and cable are installed correctly Check the installation
	Laser power supply switched off	Turn on main switch
	Software not installed correctly	Re-install software
	Software terminated irregularly	Restart PC
No laser beam	Laser not in focus	Check working distance
	Shutter is closed	Open shutter - if not possible check interlock circuit
	Incorrect laser parameters	Check the parameters in the program. Use suitable parameters for the material and application
	Focussing lens dirty	Check the lens for dirt and clean as required.
Insufficient laser output	Laser not in focus	Check working distance
	Incorrect laser parameters	Check the parameters in the program. Use suitable parameters for the material and application
	Focussing lens dirty	Check the lens for dirt and clean as required.
Missing symbols	Focussing lens dirty	Check the lens for dirt and clean as required.
	Surface of the material dirty	Clean material surface
	The marking plane is not parallel to the focussing lens	Ensure that the entire marking surface is parallel to the focussing lens
Other faults		Contact TROTEC Support

11 Maintenance

11.1 General Maintenance



CAUTION

Before any maintenance work takes place, ensure that the power supply has been switched off and the system is de-energised.



All maintenance work must be carried out according to the safety regulations.



Using explosive or flammable cleaning agents present a risk of fire or explosion:



No flammable or explosive liquids are allowed to be stored near the machine.



INFO

In order to ensure the maximum availability and lifetime of the system, we recommend you regularly check the filter system and ventilation and keep the surrounding area clean. A visual inspection of the lenses is likewise recommended before switching on the system.



11.2 Maintenance schedule

	Daily	Weekly	Monthly	Annually
System Component				
Lenses	Check If necessary clean			
Guide bar for door weights				Clean
Entire working area – general cleaning	Clean			
Visual inspection of laser protection glass for integrity	Check if necessary replace			
Function check of every individual emergency stop devices				Check
Visual inspection of the safety door cables for integrity			Every 6 month Check If necessary re- place	
Exhaust System				
Filter	According to the operation manual of the exhaust system			
Filter mat				
Activated carbon filter				

11.3 Cleaning the Lenses



INFO

Laser optics are highly sensitive and their surfaces are not as hard as traditional glass. They can also be easily damaged by cleaning. It is therefore necessary to ensure that any dirt is removed using a suitable suction device and that the surrounding area is cleaned regularly.



Never touch the optical components with your fingers! Oily or dirty hands may damage the lens surfaces.



To remove larger pieces of dirt, only use a soft lens cleaning cloth in conjunction with high proof (min. 98 %) alcohol or special lens cleaning liquid.



Do not dip the cleaning cloth in the cleaning solution. This contaminates the solution and makes it unusable. Place drops of the solution on the cloth!



Do not use any tools or hard objects to clean the surfaces. Scratches cannot be repaired.



Small bellows should be used to remove dust.
Do not use compressed air as it contains small quantities of oil and water.





Distribute the cleaning fluid carefully using small circular motions. Start at the centre of the lens and move outwards to the edge. Keep moving the cloth until the entire surface is clean.

Do not exert any pressure on the lens.

11.4 Replacing the Filter Mat

This laser system is fitted with a ventilation system. A filter mat is used to protect the electronic components from dust and dirt in the ambient air.

This filter mat should be checked and replaced at regular intervals in order to ensure optimum cooling.

The filter mat is located behind the ventilation slots on the front of the laser rack or PC.

Filter Mat Laser Rack

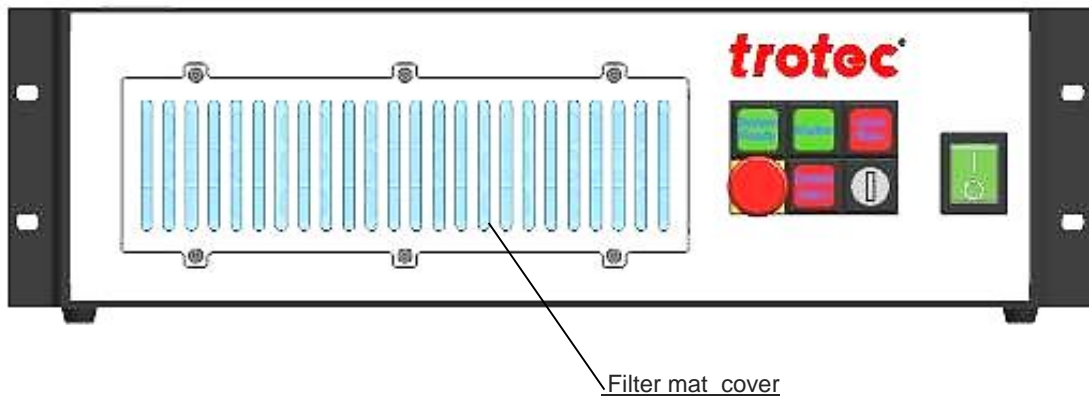

Filter Mat Industrial PC

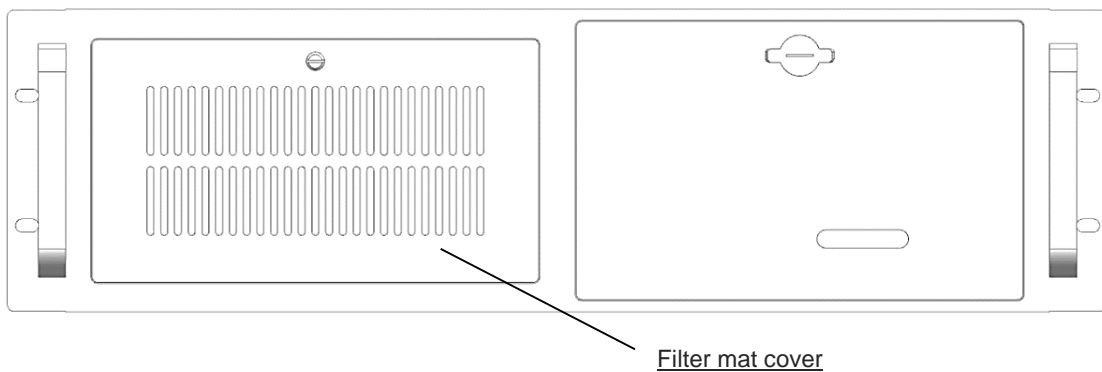

11.5 Observation window

The observation window is made of a special, coloured plastic. In order not to damage it, it should only be cleaned with clean water and possibly a little detergent if necessary. Use a soft cloth in order not to scratch the surface.

Benzene, alcohol, acetone, solvent or similar cleaning agents will damage the laser protection glass, which must be replaced immediately.

Scratches must also be avoided. The laser protection glass must be replaced immediately if it becomes scratched.

12 Disassembly



CAUTION

Injury may occur when disassembling the machine. Therefore always wear suitable protective clothing (Safety glasses, safety shoes, and so on).



CAUTION

The machine must be disconnected from the power supply.

12.1 Sequence

1. Remove all work pieces from the processing area.
2. Press the "Emergency stop" button.
3. Shut of the laser souce module
4. Switch off the main switch.
5. Remove the exhaust system.
6. Disconnect the power supply.



INFO

Always use suitable tools to disassembly the machine. Mind the springs!



Follow the special disposal instruction

